

**OWNER'S
MANUAL**

MODEL NOS.

T8505



Thank you for buying our product. We try hard to ensure that our products are of high quality and free of problems, such as manufacturing defects or missing parts. However, if you have any problems with your new product, please **DO NOT RETURN IT TO THE STORE!**

**DO NOT RETURN THIS PRODUCT TO THE
STORE!**

Call us at:

TOLL FREE 1-866-873-3528
(THIS IS A CONSUMER ONLY NUMBER)
Please have this Owner's Manual with you when you call.

Or write us at: CUSTOMER SERVICE DEPT., P.O. Box 889, Evansville, IN 47706
Fax Number: (812) 467-1399.

Or E-mail us at: customerservice@escaladesports.com

Please provide model number and/or part number (not just the key number) of the product and/or part when you call or write. These numbers can be found on the product, packaging, and/or in this Owner's Manual.

- Tools Needed:** ■ Two 7/16 Open \ Boxed End Wrenches ■ Two 1/2 Wrenches
■ Tape Measure ■ Two 9/16 Open \ Boxed End Wrenches

Hardware Identifier

(NOTE: This hardware shown actual size. For specific information, see Product Parts List on back.)

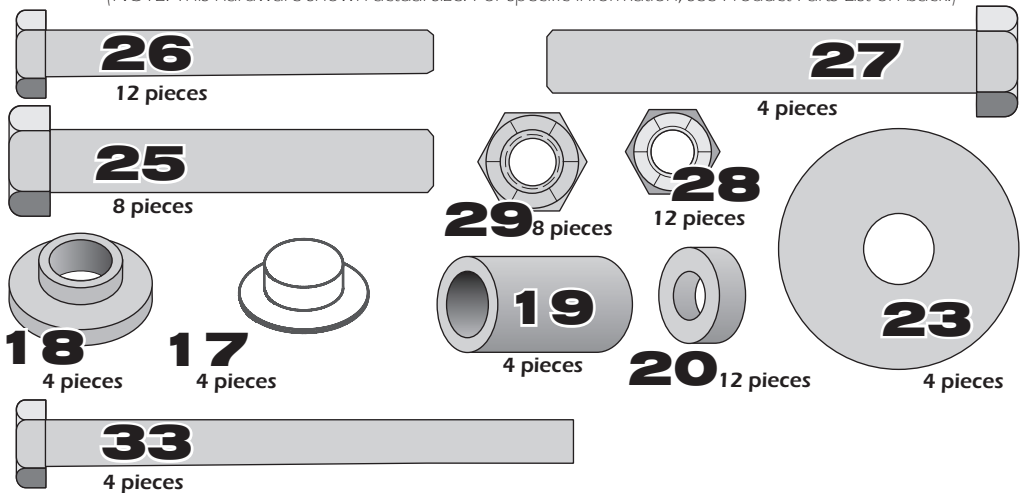

**READ THESE
INSTRUCTIONS
CAREFULLY!**

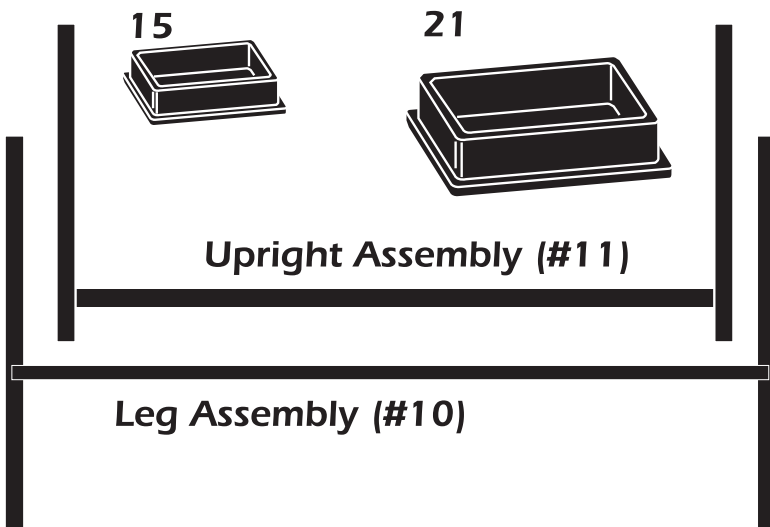

(NOTE:
These parts are shown reduced in size.)

**Name Panel (#8) &
Safety Latches (#9)**



Caster Beam (#12)



Linkage (#24)



ATTACHING LEGS TO TABLE TOPS



CAUTION: AT LEAST TWO ADULTS ARE NEEDED TO COMPLETE THE FOLLOWING STEPS!

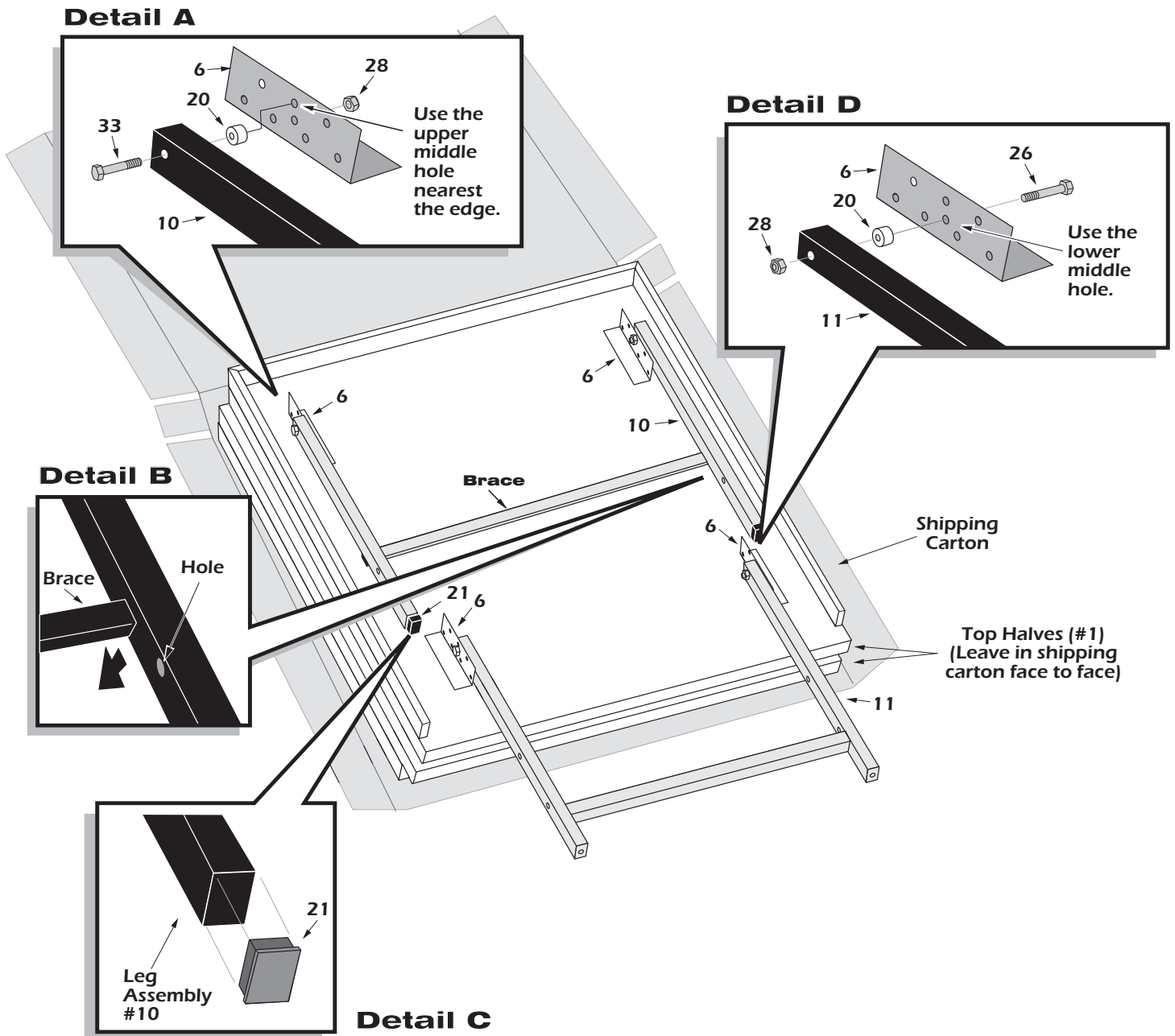

1. Leave top halves #1 in shipping carton as shown above or lay them on a carpeted floor (to protect them from damage and scratches).
2. Attach leg assembly #10 to brackets #6 located on the bottom of the first top half #1. (See above). Use bolts #33, spacers #20 and locknuts #28. (See Detail A).
NOTE: Be sure brace on leg assembly #10 is against table. (See Detail B). Tighten these locknuts snug but **DO NOT OVERTIGHTEN THEM. JOINT MUST MOVE!**
3. Put caps #21 on bottom end of leg assembly #10.

- (See Detail C).
4. Attach upright assembly #11 to remaining brackets #6 on the bottom of the first top half #1. (See above). Use bolts #26, spacers #20, and locknuts #28. (See Detail D). Tighten locknuts snug but **DO NOT OVERTIGHTEN THEM. JOINT MUST MOVE!**
 5. **With a helper**, set the first top half #1 on its side against a wall. (Be sure to put a piece of cardboard, cloth, or carpeting on the floor first to protect the top's edges.) Turn the second top half #1 over and repeat steps 2-4.

ATTACHING NAME PANELS TO LEGS



CAUTION:

AT LEAST TWO ADULTS ARE NEEDED TO COMPLETE THE FOLLOWING STEPS! DO NOT LEAVE TABLE UNATTENDED UNTIL ASSEMBLY IS COMPLETE!

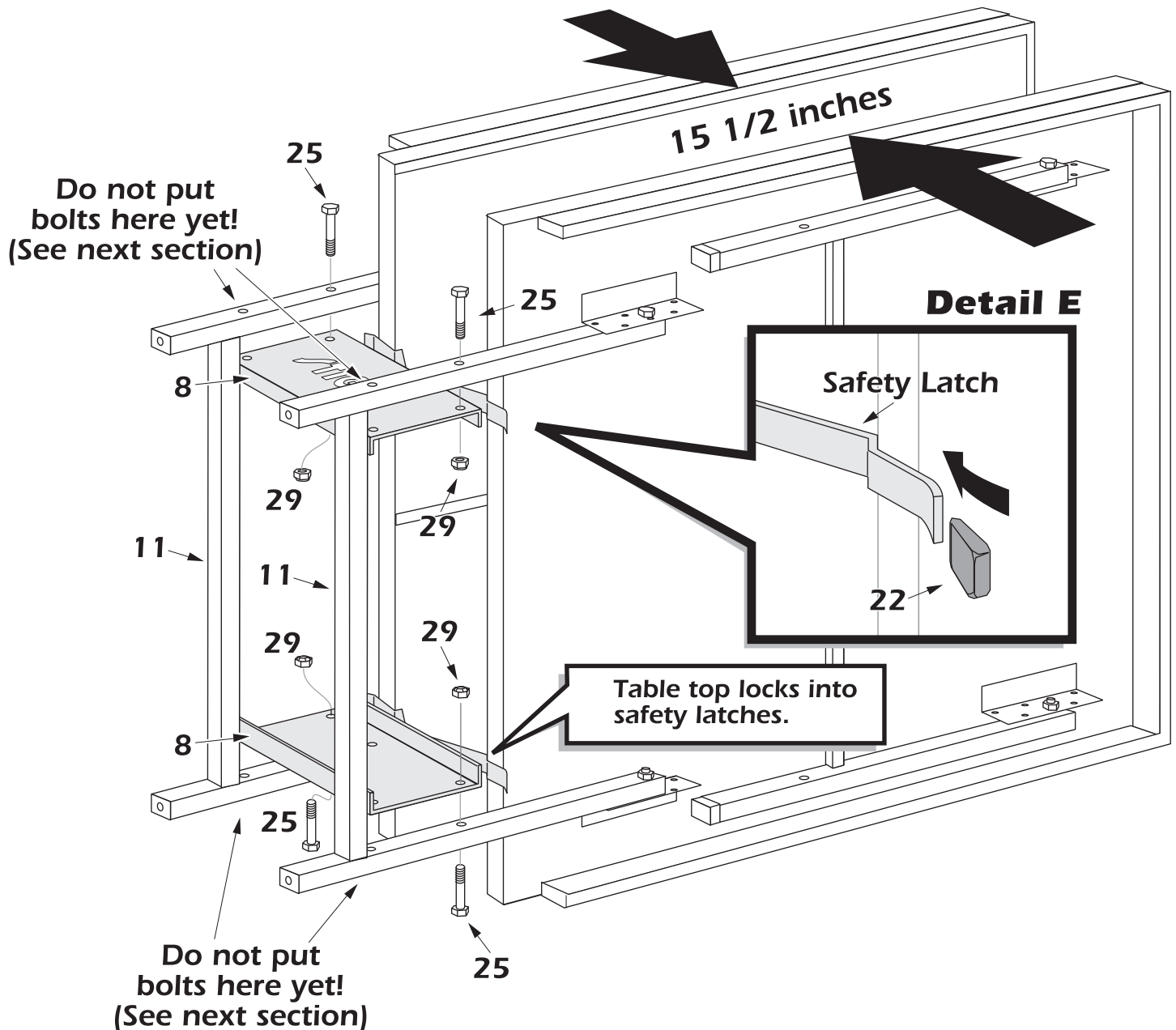

6. With a helper, put both top halves about 15 1/2 inches apart. Attach only one half of name panels #8 to upright assemblies #11 as shown above. Use **ONLY TWO** bolts #25 and locknuts #29 on each name panel.

(Two other bolts #27 and nuts #29 will be used in the next section to attach the lower half of the name panels and linkages #24 at the same time. See next page.) Do not tighten these locknuts completely tight yet.

HELPFUL HINT: Start at the bottom and insert two bolts #25 **UPWARD** through upright assemblies #11 and name panel #8. Then attach the upper name panel #8. Insert bolts #25 **DOWNWARD**.

NOTE: Be sure that top halves #1 lock into the safety latches located on each name panel #8.

7. Slide caps #22 onto ends of safety latches. (See Detail E).

Detail G

Detail F

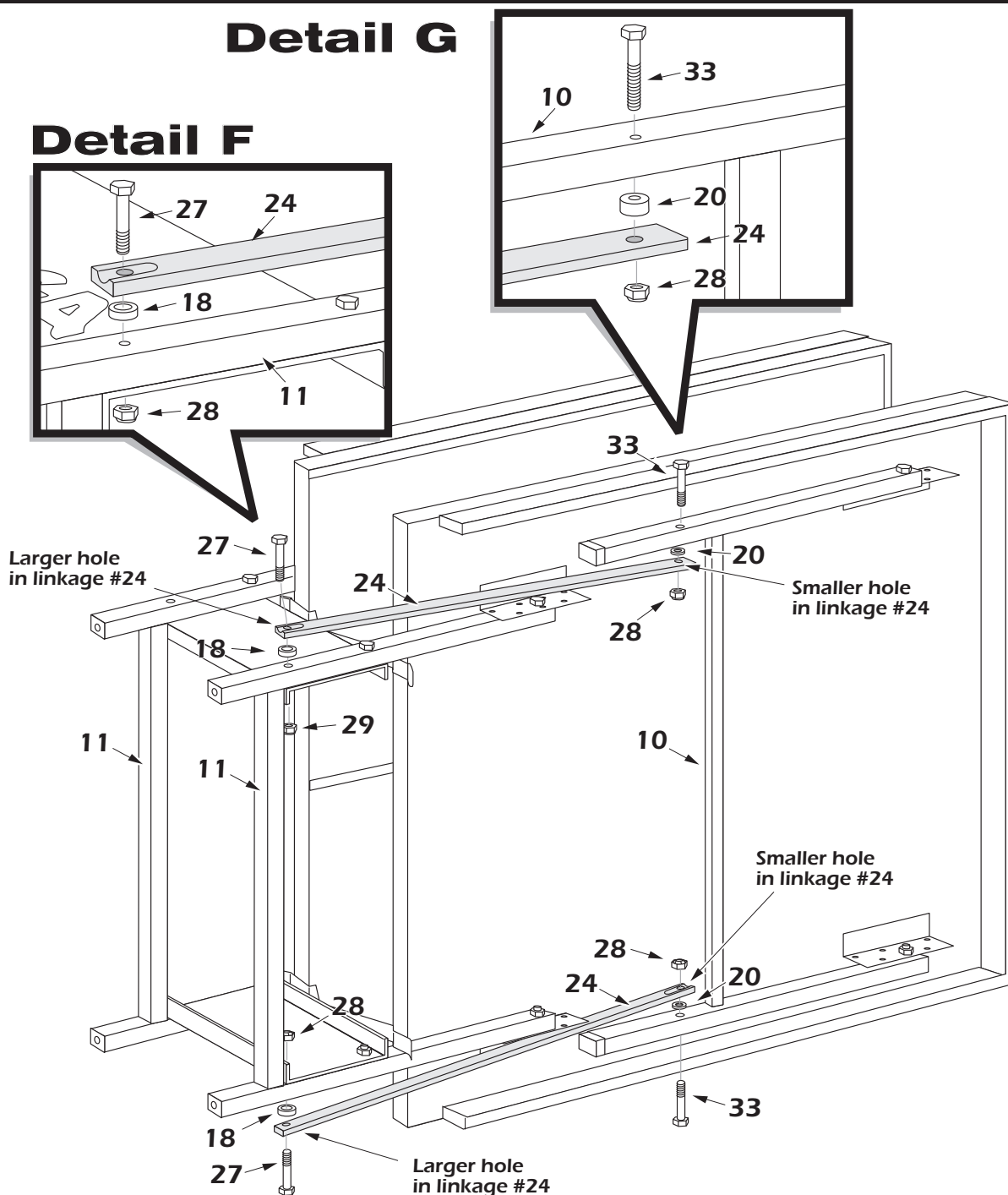

8. Attach linkages #24 to upright assembly #11 using bolts #27, step spacers #18, and locknuts #29. (See Detail F). **NOTE:** The lip on the step spacers #18 fits **INTO THE LARGER HOLE** in linkages #24. **HELPFUL HINT:** Hold your wrench upright as shown here when tightening the locknut on bolts #27. Tighten locknuts snug but **DO NOT OVERTIGHTEN THEM. THIS JOINT MUST BE ABLE TO MOVE!** **NOTE:** If you have trouble

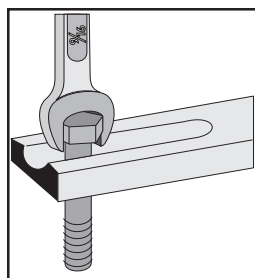

- inserting bolts #27 through name panels #8, slightly loosen bolts #25 (that you used in the previous section to attach name panels #8). (See Section 2 on previous page).
9. Attach other end of linkages #24 to leg assembly #10 using bolts #33, spacers #20, and locknuts #28. (See Detail G). Tighten these locknuts snug, but **DO NOT OVERTIGHTEN THEM. THIS JOINT MUST BE ABLE TO MOVE!**
10. Repeat steps 8 and 9 on other top half #1.

ATTACHING CASTERS

11. Put caps #15 into ends of caster beams #12 (see Detail H).

12. Attach one **non-locking** caster #13 and one **locking** caster #14 to each caster beam #12 with push nuts #17. (See Detail H). Note: Use a hammer to tap push nuts onto casters securely.

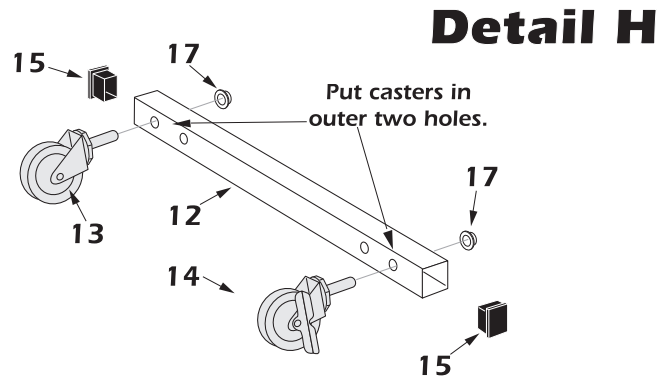

13. Attach caster beams to upright assemblies #11 with bolts #25, washers #23, and spacer bushings #19.

NOTE: Spacers bushings #19 slide **INSIDE** caster beams #12 to keep beams from crushing. (See Detail J). Tighten bolts #25 tight.

14. Lock both locking casters #14. (See Below).

NOTE: Casters should always be locked unless moving table.

Detail J

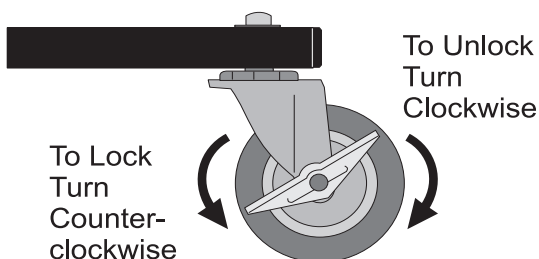
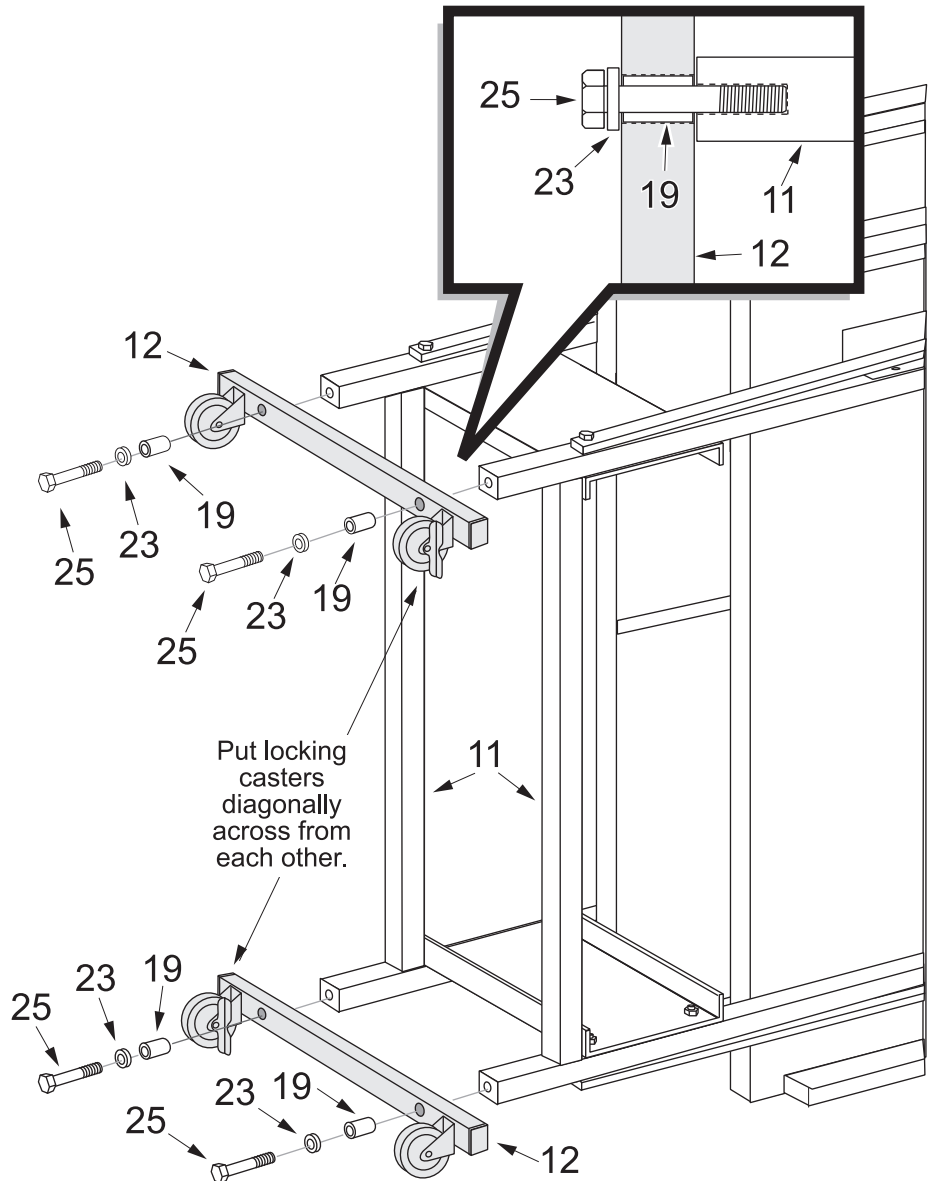

SETTING TABLE UPRIGHT



CAUTION:

At least two adults are needed to complete the following steps. Be sure top halves are locked in safety latches! Be sure that both locking casters are locked! You must use a 7" stack of magazines (or similar block) to protect the casters when lifting table upright!

Detail K

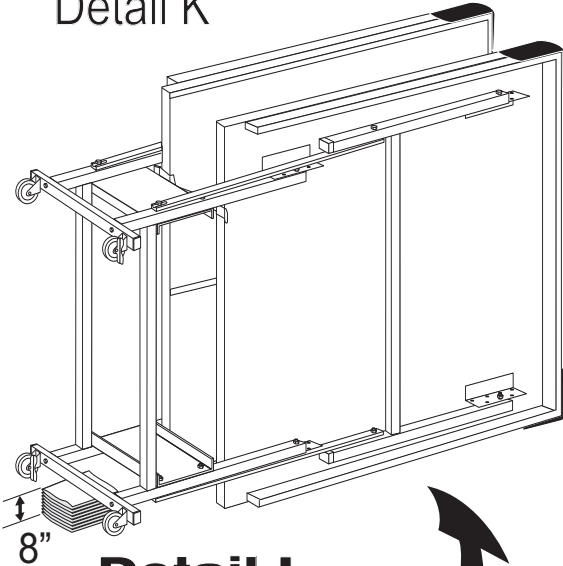

Detail L

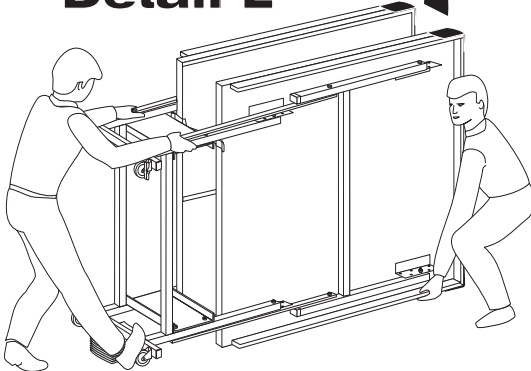

Detail M

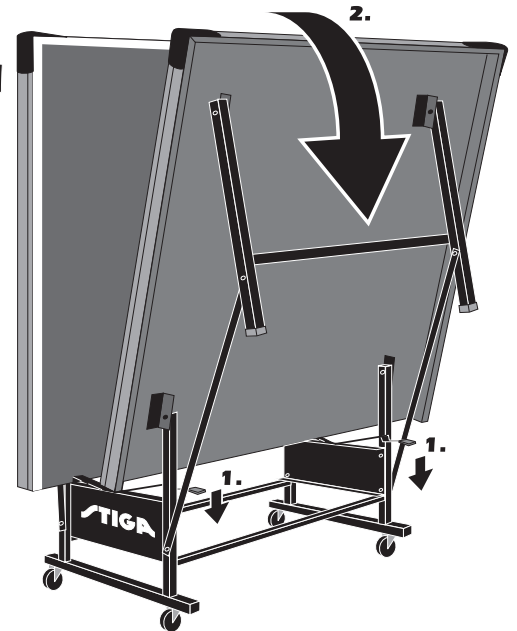

15. Before lifting table, be sure both top halves are locked in safety latches! Be sure casters are locked! Put a 8 inch stack of magazines, wood, etc. under caster beam nearest the floor to protect casters. (See Detail K).
16. With the help of one other adult, brace lower caster beam with your foot and lift table upright. (See Detail L).
17. Once upright, release both safety latches at the same time and lower table top halves. (See Detail M and **OPERATING INSTRUCTIONS** on next page).

MAKING FINAL ADJUSTMENTS

18. Loosen the six bolts shown and adjust table so that the space between the two table top halves measures $5/16$ of an inch.
19. Retighten these bolts.
20. Check over entire assembly to be sure all nuts and bolts are secure. Remember, do not overtighten bolts at joints that move.

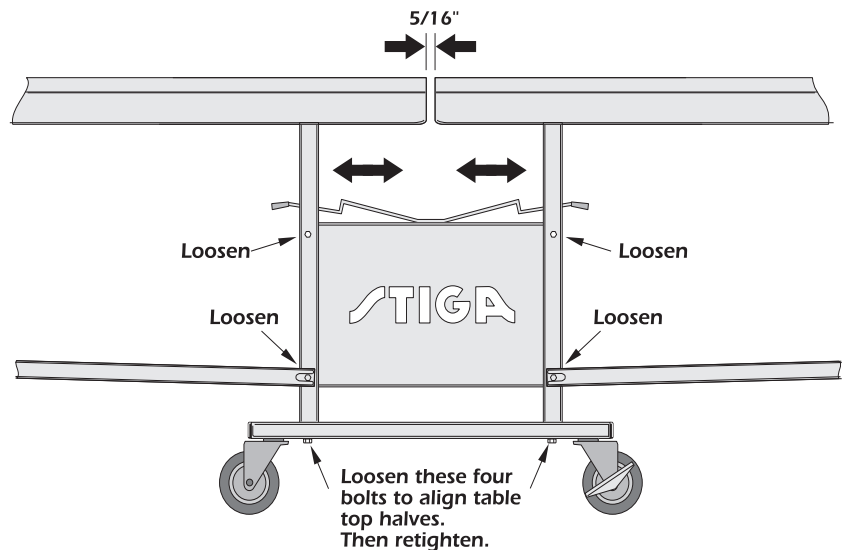

FINISHING THE ASSEMBLY

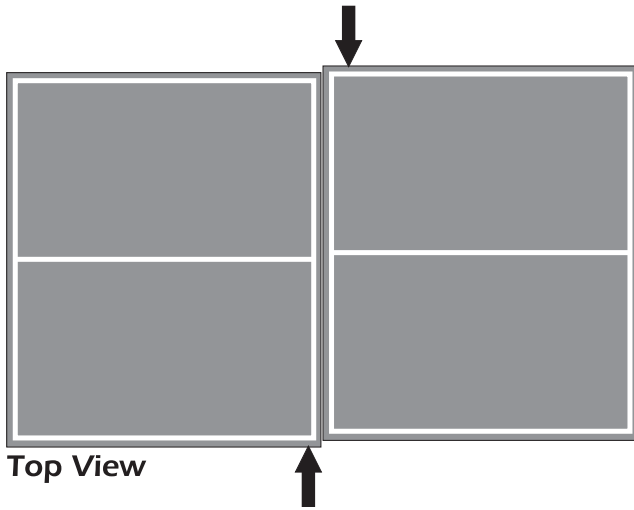

NOTE:

If sides of table are not even with one another, loosen the bottom four bolts that were loosened in step #18 and push both sides inward as shown until they are even. Retighten bolts when sides are even.

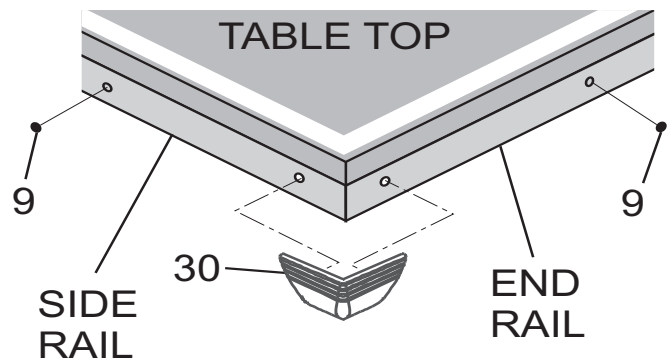

21. Put hole plugs #9 into the small holes in the side and end rails (located around the table just under the table tops). There are a total of twelve holes, two holes per rail.

22. Attach the four Corner Protectors #30 to the corners of table tops. Push snap tabs on Corner Protectors into holes in Rails.

OPERATING INSTRUCTIONS



CAUTION:

- ALWAYS LOCK TABLE TOP HALVES IN SAFETY LATCHES WHEN STORING, MOVING, OR USING TABLE IN ITS PLAYBACK POSITION!
- ALWAYS LOCK CASTERS, EXCEPT WHEN MOVING TABLE!
- DO NOT SIT, STAND, WALK OR JUMP ON THIS TABLE!
- DO NOT ALLOW CHILDREN TO PLAY ON OR NEAR TABLE! SERIOUS OR FATAL INJURY COULD RESULT!

Two-man Opening



To open table:

1. Lock both locking casters.
2. With the aid of another adult, hold table half with one hand and release safety latches (both at the same time).
3. Open table half slightly, until free of safety latches.
4. With both hands on table half, lower table top half.
5. Repeat on other half.

To close table:

1. Be sure both locking casters are locked.
2. Lift table top half until edge of table half locks securely in safety latches.
3. Check to be sure that top is locked in safety latches.



DO NOT ALLOW CHILDREN TO PLAY ON OR AROUND TABLE! SERIOUS OR FATAL INJURY COULD RESULT!

Playback Position

Top locked in safety latches.

Lock caster.

Closed or Storage Position

Top locked in safety latches.

Top locked in safety latches.

Lock caster.

Open or Playing Position

Lock caster.

CAUTION

This table must be kept indoors to prevent damage to the playing surface. Dampness and extreme temperature changes which occur on patios, or similar areas, can cause wood to warp, swell, crack or blister.

UNEVEL FLOORS: If your table does not seem level, it is probably because the floor is not level. Move table around several inches to find the best location for the table (first be sure table is in playing position). If floor is extremely unlevel, the table may not play or operate properly. If the table is high in the center, shim up under leg assemblies.

Use **PART #** column when calling for replacement parts.

PRODUCT PARTS LIST

QTY. column refers to the total number of pieces in product.

ITEM #	PART #	DESCRIPTION	QTY	ITEM #	PART #	DESCRIPTION	QTY
1	4A-6324-01	Table Top Half	2	16	2L-7121-00	Owner's Manual	1
2	2S-6715-05	Side Rail - Right	2	17	601-84	3/8 Pushnut	4
3	2S-6716-05	Side Rail - Left	2	18	701-202	Step Spacer	4
4	2S-6714-00	End Rail	2	19	701-203	Spacer Bushing	4
5	2S-6146-00	Stiffener	2	20	704-104	Spacer	12
6	2S-6139-01	Mounting Bracket	8	21	3M-6248-00	Leg Cap	4
7	701-105	#8 x 9/16 Screw	114	22	704-135	Safety Latch Cap	4
8	4A-6161-07	Name Panel & Safety Latch Ass'y	2	23	901-37	3/8 Heavy Washer	4
9	701-139B	Hole Plug	12	24	8S-6801-00	Linkage	4
10	1A-7010-01	Leg Assembly	2	25	901-18	5/16-18 x 2 Hex Head Bolt	8
11	1A-7008-01	Upright Assembly	2	26	701-82	1/4 -20 x 2 Hex Head Bolt	4
12	703-107NB	Caster Beam	2	27	801-66	5/16-18 x 2-1/4 Hex Head Bolt	4
13	2Q-6461-00	Caster (Non-locking)	2	28	701-26	1/4 -20 Locknut	12
14	2Q-6462-00	Caster (Locking)	2	29	2B-6009-02	5/16-18 Locknut	8
15	704-140	Tube Plug	4	30	3M-6715-00	Corner Protector	4
				33	1B-6191-00	1/4-20 x 2 3/4 Hex Head Bolt	8

Care and Maintenance: You have purchased a quality product that will give you years of enjoyment. By following these simple steps you will add to the life of your new table.

IMPORTANT NOTE ABOUT TOP: The top (playing surface) of your table is of a special (particle board) construction. Like all wood products it can be affected by atmospheric changes, meaning both temperatures and humidity. This may cause a slight sag, or distortion as the top expands or contracts. This is normal and is no cause for concern as it does not detract from the play or utility value of the table. To minimize this sag, always store table in a dry area, in the folded up position.

Storage for your table: This table must be stored indoors to prevent damage to the playing surface. Dampness and extreme temperature changes can cause the wood to warp, swell, crack, or blister. When your table is not in use, it must be folded up in a dry area.

Cleaning your table: To clean your table use a soft damp **NOT WET** cloth only. To prevent damage to your table's playing surface **DO NOT** use any chemicals, abrasive, or cleaning products on your table's playing surface.

Maintenance for your table: Be sure to oil all moving parts of your table, including pivot points. This will insure the safety and ease of use of your table.

LIMITED 1 YEAR WARRANTY

Manufacturer warrants to the original retail purchaser, this product to be free from defects in material and workmanship for a period of one (1) year from the date of purchase. Should this product become defective due to material or workmanship within the warranty period, contact our Customer Service Department. If defective by the terms of this warranty, we will, at our option, repair or replace the product. This warranty is not transferable and does not cover normal wear and tear, or damage caused by improper handling, installation or use of this product. This warranty is also void if product is in any way abused, damaged, or modified from its original state, or if used for other than residential use. This warranty gives you specific legal rights, and you may have other rights which vary from state to state.

NOTE: Not all parts shown below. At least one of every part listed in the Product Parts List is shown and marked by its Item Number.

